



**RSV + Flu A/B + COVID  
Home Test  
Package Insert**

<b>REF</b> L03A-R1445	<b>REF</b> L03A-R1545	<b>English</b>
<b>REF</b> L03A-R1645	<b>REF</b> L03A-R1745	

A rapid test for the detection and differentiation of respiratory syncytial virus (RSV), Influenza A, Influenza B, and/or SARS-CoV-2 antigens in anterior nasal specimens. For *in vitro* diagnostic use only. For Over-the-Counter Use.

**Carefully read all instructions before performing the test. Failure to follow the instructions may result in inaccurate results. An anterior nasal swab sample can be self-collected by an individual aged 14 years or older. Children aged 6 months-13 years should be tested by adults.**

**INTENDED USE**

The Flowflex Plus RSV + Flu A/B + COVID Home Test is a lateral flow immunoassay intended for the qualitative detection and differentiation of respiratory syncytial virus (RSV), influenza A, influenza B, and SARS-CoV-2 protein antigens directly in anterior nasal swab samples from individuals with signs and symptoms of respiratory tract infection. Symptoms of respiratory infections due to RSV, influenza, and SARS-CoV-2 can be similar.

This test is for non-prescription home use by individuals aged 14 years or older testing themselves, or adults testing individuals aged six (6) months or older.

All negative results are presumptive and should be confirmed with an FDA-cleared molecular assay when determined to be appropriate by a healthcare provider. Negative results do not rule out infection with RSV, influenza, SARS-CoV-2 or other pathogens.

Individuals who test negative and/or experience continued or worsening symptoms, such as fever, cough and/or shortness of breath should therefore seek follow-up care from their healthcare provider.

Positive results do not rule out co-infection with other respiratory pathogens and therefore do not substitute for a visit to a healthcare provider or appropriate follow-up.

**SUMMARY AND EXPLANATION**

RSV Respiratory Syncytial Virus (RSV) is a common respiratory disease infecting the lungs and respiratory tract. Symptoms include coughing, sneezing, runny nose, fever, and loss of appetite. RSV is contagious and can spread from an infected person through viral transmission. Cases of RSV are more likely to occur in infants and individuals older than 65 with weakened immune systems from other health problems such as heart or lung disease. Most children will develop RSV in their first or second year. The incubation period (time from

infection to developing symptoms) for RSV ranges from 2 to 8 days, which may differ by variant. Most individuals infected with RSV show symptoms within 4 to 6 days of exposure based on epidemiological studies. Recovery from the disease typically takes about 1-2 weeks, but severe RSV can cause pneumonia and bronchiolitis requiring hospitalization.

Influenza (Flu) is an acute respiratory disease caused by Flu viruses (type A, type B and type C), which is highly infectious and has a short window period. Flu A virus poses a greater risk as compared to Flu B virus. Based on the current epidemiological investigation, the incubation period is generally 1 to 7 days, most of which are 2 to 4 days. Flu patients usually have symptoms of high fever, headache, muscle pain and fatigue, accompanied by respiratory symptoms, such as sore throat, cough, and sputum. Most infections go away on their own, but infants, the elderly, and patients with underlying cardiopulmonary diseases are prone to severe complications such as pneumonia that can lead to death.

Both RSV and influenza viruses are known to cause seasonal epidemics of respiratory illness. Testing outside the typical RSV and flu season increases the risk of false results.

The novel coronaviruses belong to the  $\beta$  genus<sup>1</sup>. COVID-19 is an acute respiratory infectious disease. People are generally susceptible. Currently, the patients infected by the novel coronavirus are the main source of infection; asymptomatic infected people can also be an infectious source. Based on the current epidemiological investigation, the incubation period is 1 to 14 days, mostly 3 to 7 days. The main manifestations include fever, fatigue and dry cough. Nasal congestion, runny nose, sore throat, myalgia and diarrhea are found in a few cases<sup>2</sup>.

## PRINCIPLE

The Flowflex Plus RSV + Flu A/B + COVID Home Test is a qualitative membrane based chromatographic immunoassay for the qualitative detection and differentiation of the nucleocapsid protein antigens from RSV, Influenza A, Influenza B, and/or SARS-CoV-2 in human anterior nasal swab specimens from those suspected of RSV, Influenza A, Influenza B, and COVID-19 infection. The Flowflex Plus RSV + Flu A/B + COVID Home Test is validated for testing without transport media.

When specimens are processed and added to the test cassette, RSV, Flu A/B, or SARS-CoV-2, antigens, if present in the specimen, will react with the colored anti- RSV, anti-Flu A/B, or anti-SARS-CoV-2 antibody-coated particles, which have been pre-coated on the test strip. The antigen-antibody complex then migrates toward the membrane by capillary action. This complex is then captured by a different set of anti-RSV, anti-Flu A/B, or anti-SARS-CoV-2 monoclonal antibodies immobilized at the related test line region, and a colored line appears on the membrane.

Test results are interpreted visually at 15-30 minutes based on the presence or absence of visually colored lines.

To serve as a procedure control, a red or pink line will always appear in the control line region after proper volume of specimen has been added, and membrane wicking has occurred.

## REAGENTS AND MATERIALS

### Materials Provided

Kit Component	Quantity	Description
Test Cassettes	1, 2, 5 or 25 individually wrapped for single use	Foil pouched test cassette containing one reactive strip pre-coated with monoclonal anti-SARS-CoV-2 and anti-Flu A/B antibodies and one reactive strip pre-coated with monoclonal anti-RSV antibodies
Extraction Buffer Tube	1, 2, 5 or 25 single use buffer tubes, each with an integral dispensing tip	Detergent solution with 0.1% ProClin 300 & 1% Tris
Sterile Nasal Swabs	1, 2, 5 or 25 sterile swabs, single use specimen sampling swabs	For sample collection and transfer
Pediatric Swab Guard	1, 2, 5 or 25 single use swab guard attachment	For safe nasal swab sample collection from 6 months – 23 months aged users
Tube Holder	Only for 25 test quantity	Each holder has capacity for 10 extraction buffer tubes
Quick Reference Instructions	1 English QRI 1 Spanish QRI	

### Materials Required But Not Provided

- Timer

## REAGENT STORAGE

- The kit should be stored at temperatures between 36-86°F (2-30°C) out of direct sunlight.
- The test must remain in the sealed pouch until use and should be run at temperatures between 59-86°F (15-30°C).
- The test is stable until the expiration date printed on the sealed pouch.
- DO NOT FREEZE.

## QUALITY CONTROL

Internal procedural controls are included in the test. A red or pink line appearing in the control line regions (Ctl) is an internal procedural control. The appearance of the procedural control lines indicates that proper volume of specimen has been added, and capillary flow occurred. If the procedural control lines do not develop in 15 minutes, the test result is considered

invalid, and retesting with a new cassette is recommended.

## WARNINGS AND PRECAUTIONS

- **Do not use the test if you have had symptoms for more than 5 days or no symptoms at all.**
- **Do not use the test on anyone under 6 months of age.**
- **Users aged 6 – 23 months must use swab guard during collection to reduce risk of injury.**
- **Users aged 6 – 23 months must have at least two adults present to appropriately perform sample collection.**
- All viruses tested by this test can cause severe disease, especially RSV in infants and young children.
- **Certain people should not use this test. These people could get much sicker very quickly or even die if they don't get medical help right away: persons showing signs or symptoms of ongoing severe disease, [e.g., short and shallow breathing, flaring of the nostrils or straining (retractions) of the chest or stomach while breathing, or turning blue around the lips and fingertips advance disease] infants born prematurely (birth before 29 weeks of gestation), certain types of congenital chronic lung or heart disease, neurologic or neuromuscular conditions especially those who have difficulty swallowing or clearing mucus secretions. If you or your child have any of these conditions, see a healthcare provider right away instead of using this test.**
- Infants and young children can get hurt more easily when collecting the nose swab sample. If the swab is not used the right way, it could hurt the inside of the nose, causing nosebleeds. It could also mean not getting enough sample to test properly, which might provide the wrong test results.
- If your infant has received monoclonal antibodies (e.g., Clesrovimab-cfor), you may need a healthcare provider to interpret test results.
- This product is used only for the detection and differentiation of protein antigens from respiratory syncytial virus (RSV), influenza A, influenza B, and SARS-CoV-2, not for any other viruses or pathogens. This product does not detect influenza C.
- Do not use the test after the expiration date shown on the test cassette pouch or if the test kit contents are damaged or opened.
- Do not touch the nasal swab head during sample collection. Accidental contamination can lead to inaccurate results. Repeat sample collection with a new test kit if swab head touches another surface.
- The swab specimen should be processed and tested immediately after collection.
- Once opened, the test cassette should be used immediately.
- **Do not read test results before 15 minutes or after 30 minutes. Results read before 15 minutes or after 30 minutes may lead to a false positive, false negative, or invalid result.**

- Test components are single-use. Do not re-use the test cassette, buffer, guard, or swab.
- Testing should be performed in an area with good lighting.
- Do not use this test if you have recently received a nasally administered influenza A or B vaccine.
- Remove any piercings from nose before starting the test.
- **Keep testing kit and components away from children and pets before and after use. Avoid contact with your skin, eyes, nose, and mouth. Do not ingest any kit components as the reagent solution contains harmful chemicals (see Hazardous Ingredients for the Reagent Solution Table).**
- **If the reagent solution contacts the skin, eyes, nose, or mouth, flush with large amounts of water.**
- **If irritation persists, seek medical advice:**  
<https://www.poisonhelp.org> or 1-800-222-1222

Hazardous Ingredients for the Reagent Solution			
Hazard Category (mixture)	GHS Hazard Statement for mixture	Labeling of Harm(s)	Hazardous Ingredients (%)
2	Skin irritation	Causes skin irritation (H315)	<ul style="list-style-type: none"> <li>• Proclin 300 / 0.1%</li> <li>• Tris / 1%</li> </ul>
2	Eye irritation	Causes eye irritation (H320)	<ul style="list-style-type: none"> <li>• Proclin 300 / 0.1%</li> <li>• Tris / 1%</li> </ul>

## PREPARATION

Carefully read all instructions before performing the test. Failure to follow the instructions may result in inaccurate results.

1. Wash or sanitize hands. Dry hands before testing.

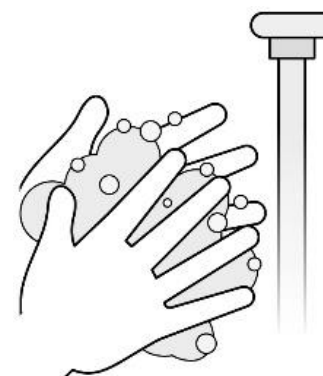

2. Remove the test cassette from pouch and lay on a clean, flat surface. Locate the Result Window and Sample Well on the cassette.

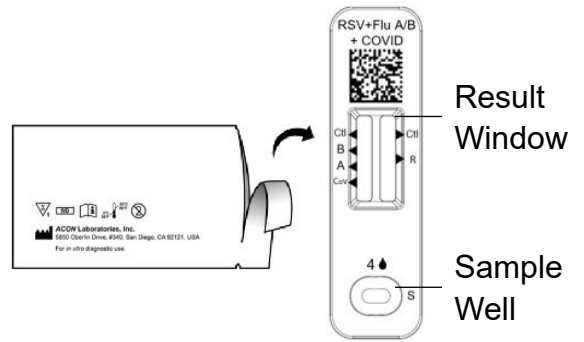

3. Remove buffer tube from pouch. Remove the foil from tube.

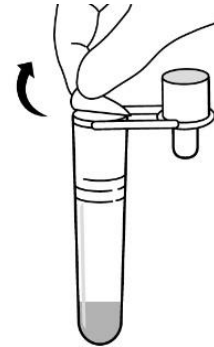

4. Punch through perforation on box to form a tube holder. Place tube in holder.

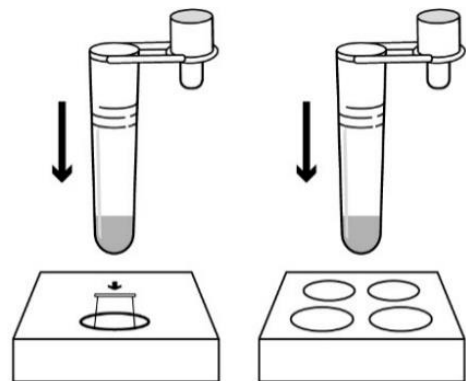

## TEST PROCEDURE FOR INFANTS (6 MONTHS – 23 MONTHS)

1. Open swab package at stick end. Take out swab. Open swab guard package. Take out swab guard. **Do not touch the swab tip.**

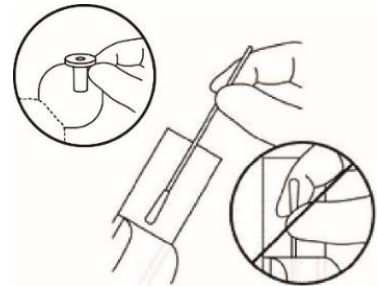

2. Slide the guard into the nasal swab through the guard opening from the stick end. **Push guard to the top of the swab until guard clicks into place at the bottom of the foam head.**

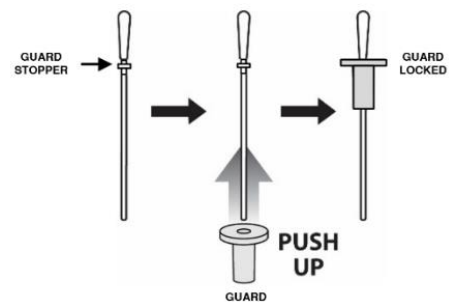

3. Position the child comfortably on the adult's lap. The adult should cross one arm over the child's body to hold their arms securely. Place the other hand on the child's forehead, tilting head backwards slightly.



4. Another adult gently inserts swab into one nostril until the guard touches the nose. **If resistance is felt, do not attempt to insert swab deeper.** Rub swab in circular motion against the inside of the wall of nostril **5 times** (15 sec.) Repeat this in the other nostril. Please use a face mask when swabbing others.

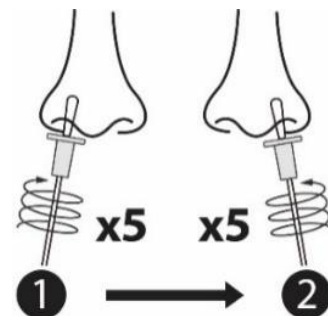

5. Place nasal swab into the extraction buffer tube. **Forcefully**, push swab into the bottom of the buffer tube to remove guard from top of nasal swab. Swirl swab in tube for **30 seconds**.

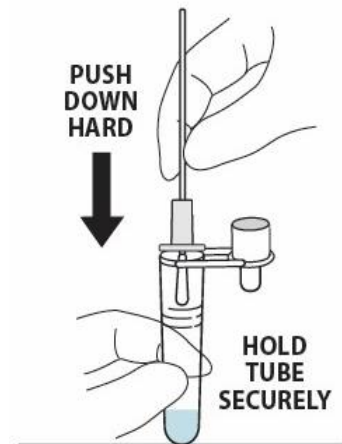

6. Rotate swab **5 times while squeezing the swab head** in the bottom of the tube. Incorrect results may be observed if the swab is not swirled for 30 seconds or rotated 5 times.

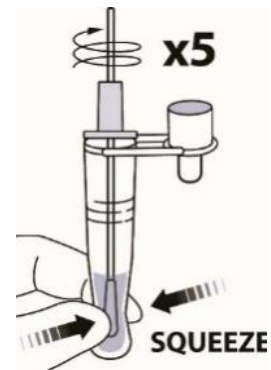

7. Remove swab while **squeezing tube** and swab head. Discard nasal swab and guard. **Note: The swab should be tested no more than 30 minutes after adding to the tube.**

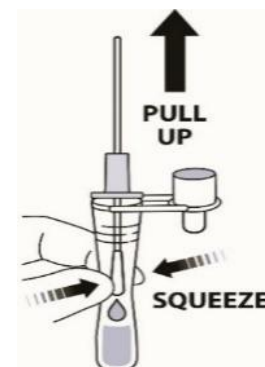

8. Attach dropper tip and mix by swirling or flicking tube.

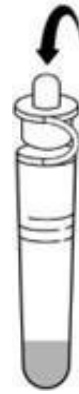

9. Gently squeeze and put **4 drops** into the sample well. Discard tube.

**Note: An invalid result may occur if less than 2 drops are added to the Sample Well.**

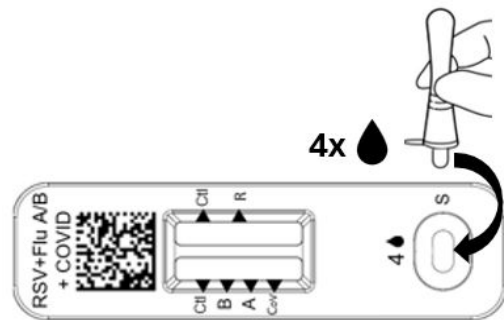

10. Set timer and read result after 15 minutes. Do not read after 30 minutes. Discard test cassette.

**Note: A false negative or false positive result may occur if the test result is read before 15 minutes or after 30 minutes.**



**15 min**

## TEST PROCEDURE (2 YEARS AND OLDER)

1. Open swab package at stick end. Take out swab. **Do not use swab guard. Do not touch the swab tip.**



2. Gently insert tip of swab into 1 nostril ( $\frac{1}{2}$  to  $\frac{3}{4}$  of an inch). **With children, insert swab less than  $\frac{3}{4}$  of an inch. You may need to have a second person to hold the child's head while swabbing. Firmly rub swab in a circular motion against the inside wall of nostril 5 times (15 sec.).** Repeat this in the other nostril using the same swab. Please use a face mask when swabbing others.

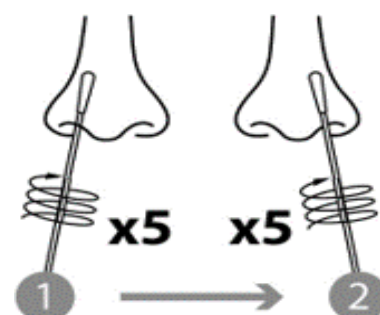

3. Remove the swab from nostril and immediately place into buffer tube. Swirl swab in buffer tube for 30 seconds.

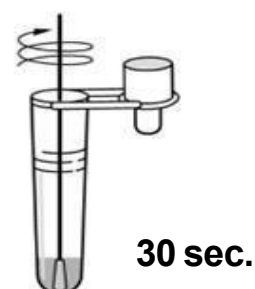

4. Rotate swab 5 times while **squeezing tube**. Incorrect results may be observed if the swab is not swirled for 30 seconds or rotated 5 times.

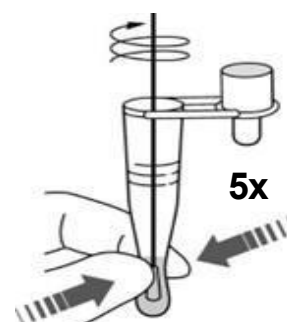

5. Remove swab while **squeezing tube**. Discard swab.

**Note: Swab with collected sample should be tested no more than 30 minutes after adding to the tube.**

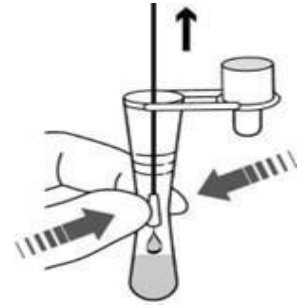

6. Attach dropper tip and mix by swirling or flicking tube.



7. Invert buffer tube and gently squeeze **4 drops of sample** into the Sample Well. Discard tube.

**Note: An invalid result may occur if less than 2 drops are added to the Sample Well.**

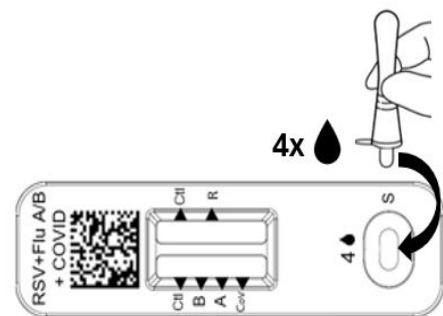

8. Set timer and read result after 15 minutes. Do not read after 30 minutes. Discard test cassette.

**Note: A false negative or false positive result may occur if the test result is read before 15 minutes or after 30 minutes.**



**15 min**

# RESULT INTERPRETATION

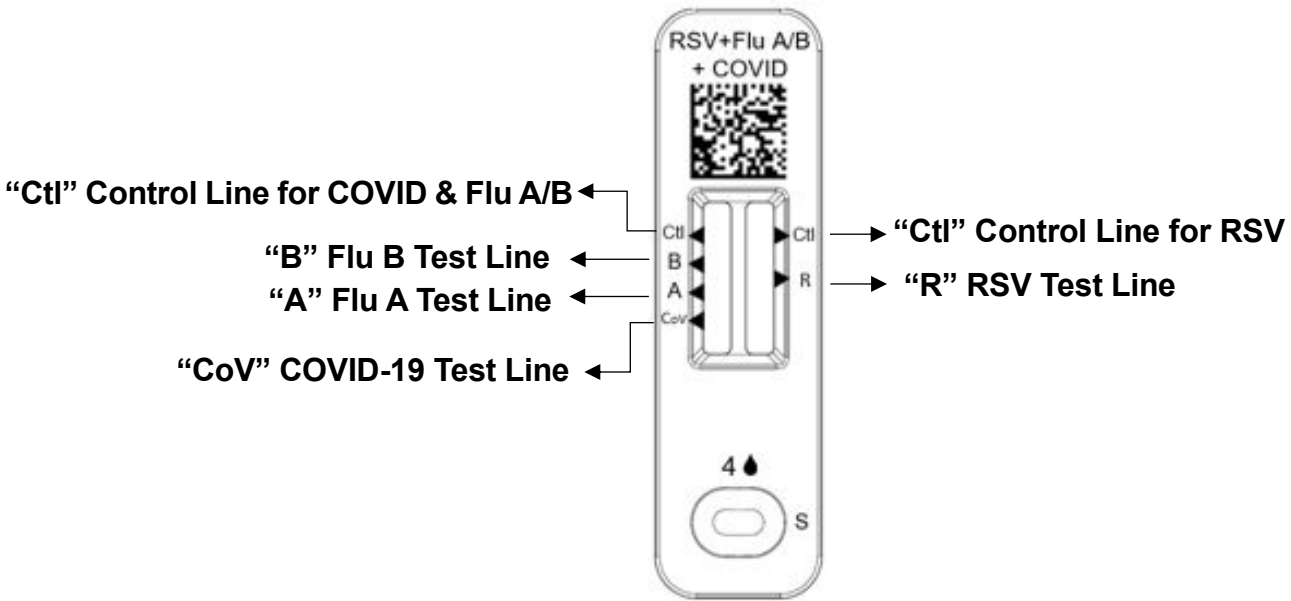

## POSITIVE

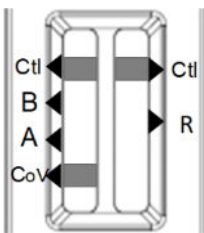

**COVID-19 Positive**

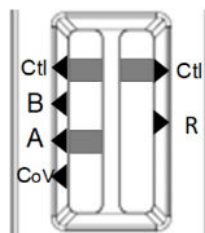

**Flu A Positive**

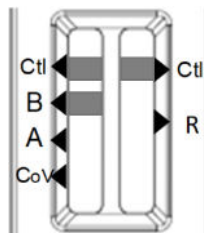

**Flu B Positive**

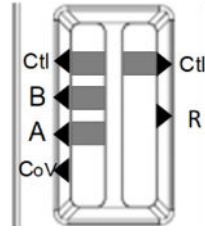

**Flu A + Flu B Positive**

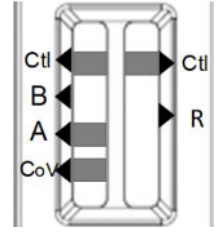

**COVID-19 + Flu A Positive**

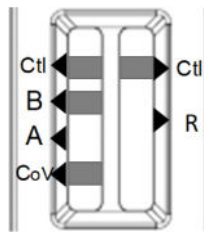

**COVID-19 + Flu B Positive**

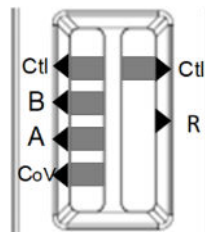

**COVID-19 + Flu A + Flu B Positive**

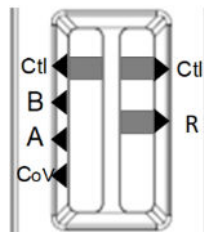

**RSV Positive**

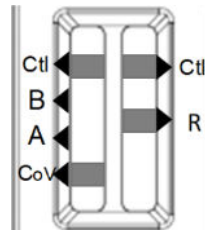

**COVID-19 + RSV Positive**

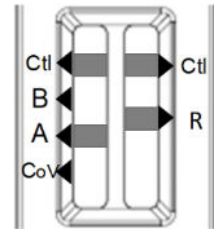

**RSV + Flu A Positive**

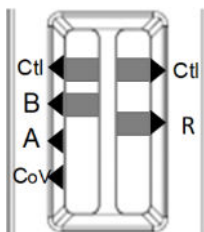

**RSV + Flu B Positive**

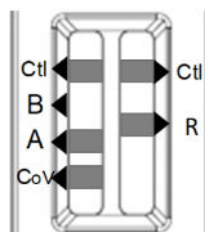

**COVID-19 + Flu A + RSV Positive**

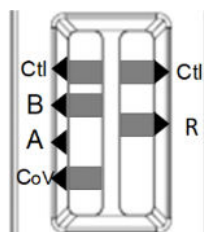

**COVID-19 + Flu B + RSV Positive**

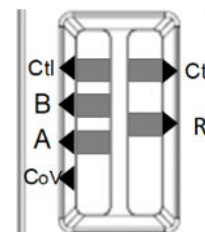

**Flu A + Flu B + RSV Positive**

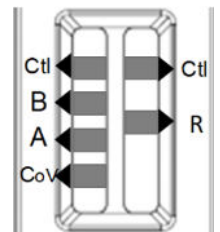

**COVID-19 + Flu A + Flu B + RSV Positive**

Note: If the Control (Ctl) line is visible on both strips and any line or multiple lines, no matter how faint, at “R”, “A”, “B”, and/or “CoV” appear, the test is positive for that virus.

**Any visible faint red or pink line in the Test line regions (R/A/B/CoV) should be read as positive for that virus.**

Please contact your healthcare provider or your local health authorities and follow local guidelines for self-isolation.

## NEGATIVE

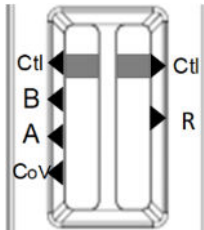

If both Control (Ctl) lines are visible, but the Test (R/A/B/CoV) line(s) is not visible, the test is negative. The RSV, Flu A, Flu B, or COVID-19 virus have not been detected.

If respiratory symptoms persist, seek follow-up care with a healthcare provider.

## INVALID

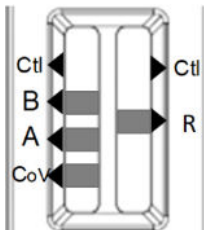

If the Control (Ctl) line is not visible on either or both test strips, even if any test line is visible in the result window, the test is invalid. Re-test with a new test kit and sample.

If the problem persists, call (800) 838-9502 for assistance.

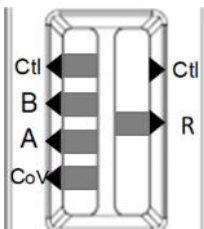

## RESULTS REPORTING

Report your test result(s) at [MakeMyTestCount.org](https://www.makemytestcount.org)-this voluntary and anonymous reporting helps public health teams understand COVID-19 spread in your area and across the country and informs public health decisions.

## LIMITATIONS

1. The performance of this test was established based on the evaluation of a limited number of clinical specimens collected between October 2024 and April 2025. There is a risk of false negative results due to the presence of novel, emerging respiratory virus variants. Test accuracy may change as new virus variants of RSV, influenza, and COVID-19 emerge. Performance at the time of testing may vary depending on the variants circulating, including newly emerging strains of RSV, influenza, and COVID-19

and their prevalence, which change over time. Additional testing with a laboratory-based molecular test (e.g., PCR) should be considered in situations where a new virus or variant is suspected.

2. A negative test result may occur if the level of antigen in the sample is below the detection limit of the test or if the sample is collected, handled or transported improperly.
3. There is a higher chance of false negative results with antigen tests than with laboratory-based molecular tests due to the sensitivity of the test technology. This means that there is a higher chance this test will give a false negative result in an individual with RSV, influenza, or COVID-19 as compared to a molecular test, especially in samples with low viral load.
4. False positive test results are more likely when the prevalence of RSV, Flu A/B, and SARS-CoV-2, is low in the community.
5. Positive results do not rule out co-infection with other respiratory pathogens.
6. Persons with risk factors for severe disease from respiratory pathogens (e.g., infants and young children, elderly individuals, chronic lung disease, heart disease, compromised immune system, diabetes and other conditions) should contact a healthcare provider; users should also contact a healthcare provider if symptoms persist or worsen, (specially for individuals 6 to 23 months of age), independently of test results or if you have any concerns.
7. This device is a qualitative test and cannot provide information on the amount of virus present in the specimen.
8. This test detects both viable (live) and non-viable RSV, influenza A, influenza B, and SARS-CoV-2. Test performance depends on the amount of virus (antigens) in the sample and may or may not correlate with viral culture results performed on the sample.
9. FluMist/FluMist quadrivalent live intranasal influenza virus vaccine may cause false positive influenza A and B results with this test.
10. This test does not differentiate between SARS-CoV and SARS-CoV-2 and does not detect influenza C.
11. The performance of this test was evaluated with a limited number of RSV positive samples from individuals aged 60 years and older.
12. This test is read visually. Because test lines can be very faint, users with conditions affecting their vision- such as far-sightedness, glaucoma, or color blindness-are encouraged to seek assistance to interpret results accurately (e.g., reading glasses, additional light source, or another person). This test has not been validated for use by those with color-impaired vision.

## **PERFORMANCE CHARACTERISTICS**

The performance of Flowflex Plus RSV + Flu A/B + COVID Home Test was established in a prospective all-comers clinical study conducted in a simulated home setting environment at ten study sites in United States. A total of 1263 anterior nasal swab samples were collected from symptomatic individuals within 5 days of respiratory symptom onset and

met the inclusion criteria for the analysis, of which 1257 samples were evaluable for COVID-19 and 1261 samples evaluable for Flu A/B and RSV respectively. The investigational nasal swab samples were either self-collected by each enrolled subject or by another adult lay user collected from a subject after the collection of the nasopharyngeal swab for comparator testing. Each subject or lay user performed the test and interpreted the result, unassisted by using only the Quick Reference Instructions. The Flowflex Plus RSV + Flu A/B + COVID Home Test results were compared to FDA cleared highly sensitive RT-PCR molecular assays to determine test performance in the tables below.

**Table 1. SARS-CoV-2 result of the Flowflex Plus RSV + Flu A/B + COVID Home Test compared to reference RT-PCR Assay**

SARS-CoV-2 Result of Flowflex Plus RSV + Flu A/B + COVID Home Test	RT-PCR for SARS-CoV-2		
	Positive	Negative	Total
SARS-CoV-2 Positive	131	1	132
SARS-CoV-2 Negative	12	1113	1125
Total	143	1114	1257*
Positive Percent Agreement (PPA)	91.6% (131/143) (95%CI: 85.9% - 95.1%)		
Negative Percent Agreement (NPA)	99.9% (1113/1114) (95%CI: 99.5% - 100%)		

\* 6 samples excluded due to invalid results with comparator methods.

**Table 2. SARS-CoV-2 Clinical Performance stratified by Days Post Symptom Onset of the Study Subject**

Days Post Symptoms Onset (DPSO)	Number of Subject Samples Tested	Candidate Positives	Comparator Positives	% Positive Rate by Comparator	PPA (95% CI)
Day 0	12	2	2	16.7%	100% (34.2%, 100.0%)
Day 1	424	40	45	10.6%	88.9% (76.5%, 95.2%)
Day 2	480	42	45	9.4%	93.3% (82.1%, 97.7%)
Day 3	202	29	31	15.3%	93.5% (79.3%, 98.2%)
Day 4	91	10	12	13.2%	83.3% (55.2%, 95.3%)
Day 5	48	8	8	16.7%	100% (67.6%, 100.0%)
<b>Total</b>	1257*	131	143	11.2%	91.6% (85.9%, 95.1%)

\* 6 samples excluded due to invalid results with comparator methods.

**Table 3. Flu A results of Flowflex Plus RSV + Flu A/B + COVID Home Test compared to reference RT-PCR Assay**

Flu A Result of Flowflex Plus RSV + Flu A/B + COVID Home Test	RT-PCR for Flu A		
	Positive	Negative	Total
Flu A Positive	236	2	238
Flu A Negative	18	1005	1023
Total	254	1007	1261*
Positive Percent Agreement (PPA)	92.9 % (236/254) (95%CI: 89.1 % - 95.5 %)		
Negative Percent Agreement (NPA)	99.8% (1005/1007) (95%CI: 99.3 % - 100 %)		

\* 2 samples excluded due to invalid results with comparator methods.

**Table 4. Flu B results of Flowflex Plus RSV + Flu A/B + COVID Home Test compared to reference RT-PCR Assay**

Flu B Result of Flowflex Plus RSV + Flu A/B + COVID Home Test	RT-PCR for Flu B		
	Positive	Negative	Total
Flu B Positive	91	1	92
Flu B Negative	7	1162	1169
Total	98	1163	1261*
Positive Percent Agreement (PPA)	92.9 % (91/98) (95%CI: 86.0 % - 96.5 %)		
Negative Percent Agreement (NPA)	99.9 % (1162/1163) (95%CI: 99.5 % - 100 %)		

\* 2 samples excluded due to invalid results with comparator methods.

**Table 5. RSV results of Flowflex Plus RSV + Flu A/B + COVID Home Test compared to reference RT-PCR Assay**

RSV Result of Flowflex Plus RSV + Flu A/B + COVID Home Test	RT-PCR for RSV		
	Positive	Negative	Total
RSV Positive	159	2	161
RSV Negative	10	1090	1100
Total	169	1092	1261*
Positive Percent Agreement (PPA)	94.1 % (159/169) (95%CI: 89.5% - 96.8%)		
Negative Percent Agreement (NPA)	99.8 % (1090/1092) (95%CI: 99.3% - 100%)		

\*2 samples excluded due to invalid results with comparator methods.

**Table 6. Subject Demographics**

Factor	Lay user collecting and testing	Self-collecting and testing	Overall
	(N=634)	(N=629)	(N=1263)
<b>Age</b>			
Mean (SD)	5.9 (4.0)	48.6 (19.6)	27.2 (25.6)
Median [Min, Max]	5 [0.5, 17]	49 (14, 91)	14 (0.5, 91)
<b>Age Group</b>			
≥ 6 months - < 2 years of age	114 (18.0%)	0 (0.0%)	114 (9.0%)
2-5 years of age	212 (33.4%)	0 (0.0%)	212 (16.8%)
6-13 years of age	296 (46.7%)	0 (0.0%)	296 (23.4%)
14-21 years of age	12 (1.9%)	75 (11.9%)	87 (6.9%)
22-59 years of age	0 (0.0%)	314 (49.9%)	314 (24.9%)
≥ 60 years of age	0 (0.0%)	240 (38.2%)	240 (19.0%)
<b>Sex at Birth</b>			
Female	300 (47.3%)	355 (56.4%)	655 (51.9%)
Male	334 (52.7%)	274 (43.6%)	608 (48.1%)
<b>Ethnicity</b>			
Hispanic/Latino	140 (22.1%)	75 (11.9%)	215 (17.0%)
Not Hispanic/Latino	494 (77.9%)	554 (88.1%)	1048 (83.0%)

### **Analytical Sensitivity: Limit of Detection (LoD)**

A limit of detection (LoD) study was conducted to determine the lowest detectable concentration of RSV, influenza A, influenza B, and SARS-CoV-2, (i.e., at least 95% of all true positive replicates are consistently detected as positive). The LoD study was determined using a two-step method: a preliminary range finding study, followed by a confirmatory LoD study. A preliminary LoD was determined by first testing serial ten-fold dilutions of live RSV A and RSV B, influenza A and B, and inactivated SARS-CoV-2 virus stocks diluted into pooled negative swab matrix (PNM) in 5 replicates per dilution and confirmatory testing was conducted with 20 replicates for 3 lots. The lowest concentration that generated ≥95% positive detection rate was set as the LoD concentration. The results of LoD confirmation testing for each virus are summarized in Table 7.

**Table 7. LoD of Flowflex Plus RSV + Flu A/B + COVID Home Test**

Virus	Subtype /Lineage	Strains	LoD Concentration (TCID <sub>50</sub> /ml)	LoD per swab (TCID <sub>50</sub> /swab)	# Positive /Total	Percent detected (%)
SARS-CoV-2	Omicron XBB	USA/CA-Stanford- 109_S21/2022	5.95 x 10 <sup>4</sup>	2.98 x 10 <sup>3</sup>	60/60	100%
	Wild-type	USA-WA1/2020	1.27 x 10 <sup>3</sup>	6.35 x 10 <sup>1</sup>	60/60	100%

Virus	Subtype /Lineage	Strains	LoD Concentration (TCID <sub>50</sub> /ml)	LoD per swab (TCID <sub>50</sub> /swab)	# Positive /Total	Percent detected (%)
Flu A	H1N1	A/Guangdong-Maonan/SWL1536/19	3.90 x 10 <sup>3</sup>	1.95 x 10 <sup>2</sup>	60/60	100%
		A/Victoria/4897/22	3.89 x 10 <sup>1</sup>	1.95 x 10 <sup>0</sup>	60/60	100%
	H3N2	A/Darwin/6/2021	1.56 x 10 <sup>2</sup>	7.80 x 10 <sup>0</sup>	60/60	100%
Flu B	Victoria	B/Hong Kong/574/19	5.01 x 10 <sup>2</sup>	2.51 x 10 <sup>1</sup>	60/60	100%
		B/Alabama/02/17	3.90 x 10 <sup>2</sup>	1.95 x 10 <sup>1</sup>	60/60	100%
	Yamagata	B/Phuket/3073/13	1.86 x 10 <sup>1</sup>	9.30 x 10 <sup>-1</sup>	60/60	100%
RSV	A	2006 Isolate	1.05 x 10 <sup>3</sup>	5.25 x 10 <sup>1</sup>	60/60	100%
	B	CH93(18)-18	4.17 x 10 <sup>2</sup>	2.09 x 10 <sup>1</sup>	59/60	98.3%

The 1st WHO International Standard for SARS-CoV-2 Antigen (NIBSC 21/368) was also tested in a similar manner to determine the LoD of SARS-CoV-2 antigen and the results are included in Table 8.

**Table 8. Analytical Sensitivity of Flowflex Plus RSV + Flu A/B + COVID Home Test with WHO International Standard for SARS-CoV-2**

Flowflex Plus RSV + Flu A/B + COVID Home Test	LoD Concentration (IU/ml)	LoD per swab (IU/swab)	# Positive / #Total replicates	Percent detected (%)
1st WHO International Standard for SARS-COV-2 Antigen	500	25	20/20	100%

### **Multi-lot Precision Study**

The multi-lot precision for the Flowflex Plus RSV + Flu A/B + COVID Home Test was evaluated in two different studies to assess variability between reagent lots, days, runs and operators.

Study 1 was conducted by 2 trained operators who each tested seven samples with various analyte concentrations and combinations (Negative, 2x LoD SARS-CoV-2, 2x LoD Flu A, 2x LoD Flu B, 2x LoD RSV, 2x LoD Flu B & RSV co-spiked, and 2x LoD SARS-CoV-2 & Flu B & RSV co-spiked). Each operator tested two sample replicates per run across two runs using three lots of devices. Runs were performed in the morning and afternoon over 10 days. This design (2 replicates/run/lot x2 runs/operator x 2 operators x 3 lots x 10 days) resulted in 240 replicates per sample. All samples were prepared in PNSM. The study was performed in

randomized and blinded manner. Results for this study are shown in Table 9 and were concordant with the expected results.

**Table 9. Summary Results for Lot-to-Lot Precision Study 1**

Sample	Analyte	Lot 1		Lot 2		Lot 3		Total % Amt	95%CI
		#Pos/Total	% Amt	#Pos/Total	% Amt	#Pos/Total	% Amt		
Negative	Flu A	0/80	100%	0/80	100%	0/80	100%	100%	98.5-100%
	Flu B	0/80	100%	0/80	100%	0/80	100%	100%	98.5-100%
	SARS-CoV-2	0/80	100%	0/80	100%	0/80	100%	100%	98.5-100%
	RSV	0/80	100%	0/80	100%	0/80	100%	100%	98.5-100%
2x Flu A	Flu A	80/80	100%	80/80	100%	80/80	100%	100%	98.5-100%
	Flu B	0/80	100%	0/80	100%	0/80	100%	100%	98.5-100%
	SARS-CoV-2	0/80	100%	0/80	100%	0/80	100%	100%	98.5-100%
	RSV	0/80	100%	0/80	100%	0/80	100%	100%	98.5-100%
2x Flu B	Flu A	0/80	100%	0/80	100%	0/80	100%	100%	98.5-100%
	Flu B	80/80	100%	80/80	100%	80/80	100%	100%	98.5-100%
	SARS-CoV-2	0/80	100%	0/80	100%	0/80	100%	100%	98.5-100%
	RSV	0/80	100%	0/80	100%	0/80	100%	100%	98.5-100%
2x SARS-CoV-2	Flu A	0/80	100%	0/80	100%	0/80	100%	100%	98.5-100%
	Flu B	0/80	100%	0/80	100%	0/80	100%	100%	98.5-100%
	SARS-CoV-2	80/80	100%	80/80	100%	80/80	100%	100%	98.5-100%
	RSV	0/80	100%	0/80	100%	0/80	100%	100%	98.5-100%
2x RSV	Flu A	0/80	100%	0/80	100%	0/80	100%	100%	98.5-100%
	Flu B	0/80	100%	0/80	100%	0/80	100%	100%	98.5-100%
	SARS-CoV-2	0/80	100%	0/80	100%	0/80	100%	100%	98.5-100%
	RSV	80/80	100%	80/80	100%	80/80	100%	100%	98.5-100%
2x Flu B & RSV	Flu A	0/80	100%	0/80	100%	0/80	100%	100%	98.5-100%
	Flu B	80/80	100%	80/80	100%	80/80	100%	100%	98.5-100%
	SARS-CoV-2	0/80	100%	0/80	100%	0/80	100%	100%	98.5-100%
	RSV	80/80	100%	80/80	100%	80/80	100%	100%	98.5-100%
2x Flu B & RSV & SARS-CoV-2	Flu A	0/80	100%	0/80	100%	0/80	100%	100%	98.5-100%
	Flu B	80/80	100%	80/80	100%	80/80	100%	100%	98.5-100%
	SARS-CoV-2	80/80	100%	80/80	100%	80/80	100%	100%	98.5-100%
	RSV	80/80	100%	80/80	100%	80/80	100%	100%	98.5-100%

Study 2 was specifically conducted to assess difference between lots using three samples, one negative sample and low positive samples at 0.75 x LoD for all analytes (0.75x LoD Flu A & SARS-CoV-2 co-spiked and 0.75x LoD Flu B & RSV co-spiked). All samples were randomized and tested in a blinded manner. The testing was carried out over 3 days only but otherwise followed the same study design as Study 1. 72 data points per sample were collected (2 replicates/run/lot x 2 runs/day x 2 operators x 3 days x 3 lots= 72 data points).

Data is summarized in Table 10. Precision is expected to be low for samples at 0.75 × LoD due to manufacturing variability, random differences across days and runs, and operator variability in reading line intensity at very low analyte concentrations.

**Table 10. Summary Results for Lot-to-Lot Precision Study 2**

Sample	Analyte	Lot 1		Lot 2		Lot 3		Total % Amt	95%CI
		#Pos/Total	% Amt	#Pos/Total	% Amt	#Pos/Total	% Amt		
Negative	Flu A	0/24	100%	0/24	100%	0/24	100%	100%	95-100%
	Flu B	0/24	100%	0/24	100%	0/24	100%	100%	95-100%
	SARS-CoV-2	0/24	100%	0/24	100%	0/24	100%	100%	95-100%
	RSV	0/24	100%	0/24	100%	0/24	100%	100%	95-100%
0.75x FluA & SARS-CoV-2	Flu A	16/24	66.7%	15/24	62.5%	13/24	54.2%	61.1%	48.9-72.4%
	Flu B	N/A	N/A	N/A	N/A	N/A	N/A		
	SARS-CoV-2	23/24	95.8%	18/24	75%	21/24	87.5%	86.1%	75.9-93.1%
	RSV	N/A	N/A	N/A	N/A	N/A	N/A		
0.75x Flu B & RSV	Flu A	N/A	N/A	N/A	N/A	N/A	N/A		
	Flu B	19/24	79.2%	22/24	91.7%	15/24	62.5%	77.8%	66.4-86.7%
	SARS-CoV-2	N/A	N/A	N/A	N/A	N/A	N/A		
	RSV	17/24	70.8%	18/24	75%	14/24	58.3%	68.1%	56-78.6%

The results of these two precision studies demonstrate that lot-to-lot precision is consistent with the expectations. The between-lot variability did not impact samples at ≥2 x LoD of the test.

### Analytical Reactivity Study

Analytical reactivity study was conducted using contrived samples prepared by spiking various strains of SARS-CoV-2 (16), Flu A (24), Flu B (8), RSV A (3) or RSV B (3) viruses into pooled nasal swab matrix (PNSM) in a series of ten-fold dilutions and three-fold dilutions tested in five replicates per the Quick Reference Instructions. Concentrations listed in the table below indicate the lowest detectable concentrations for which all 5 replicates were positive.

**Table 11. Summary of SARS-Cov-2 Analytical Reactivity with Flowflex Plus RSV + Flu A/B + COVID Home Test**

SARS-CoV-2 Subtypes	Pathogens	Concentration (TCID <sub>50</sub> /mL)	Results (#Pos/Total)
Alpha	B.1.1.7; (USA/CA_CDC_5574/2020)	3.41 x 10 <sup>5</sup>	5/5
Beta	B.1.351; (South Africa/KRISP-K005325/2020)	1.51 x 10 <sup>4</sup>	5/5
Delta	B.1.617.2; (USA/PHC658/2021)	4.17 x 10 <sup>3</sup>	5/5
Gamma	P.1; Gamma (Japan/TY7-503/2021)	8.47 x 10 <sup>4</sup>	5/5

SARS-CoV-2 Subtypes	Pathogens	Concentration (TCID <sub>50</sub> /mL)	Results (#Pos/Total)
Omicron	B.1.1.529; (USA/MDHP20874/2021)	1.29 x 10 <sup>2</sup>	5/5
	BA.2.3; (USA/MDHP24556/2022)	3.90 x 10 <sup>3</sup>	5/5
	BA.4.6; (USA/MDHP35538/2022)	1.15 x 10 <sup>4</sup>	5/5
	BA.5;(USA/COR-22-063113/2022)	2.53 x 10 <sup>4</sup>	5/5
	BF.5; (USA/MD-HP34985/2022)	8.80 x 10 <sup>3</sup>	5/5
	BF.7; (USA/NY-Wadsworth-22042128-01/2022)	1.26 x 10 <sup>4</sup>	5/5
	BQ.1; (USA/NY-Wadsworth-22050462-01/2022)	1.43 x 10 <sup>4</sup>	5/5
	BQ.1.1; (USA/MD-HP38861/2022)	2.93 x 10 <sup>3</sup>	5/5
	JN.1.4; (USA/NY-Wadsworth-23068107-01/2023)	5.43 x 10 <sup>3</sup>	5/5
	EG.5.1; (USA/MD-HP47946/2023)	1.22 x 10 <sup>4</sup>	5/5
	JG.3; (USA/NY-Wadsworth-23067147-01/2023)	7.88 x 10 <sup>4</sup>	5/5
	HV.1 USA/MD-HP49152/2023	8.73 x 10 <sup>3</sup>	5/5

**Table 12. Summary of Flu A Analytical Reactivity with Flowflex Plus RSV + Flu A/B + COVID Home Test**

Flu A Subtype	Pathogens	Concentration (TCID <sub>50</sub> /mL)	Results (#Pos/Total)
H1N1	A/California/07/09	1.70 x 10 <sup>2</sup>	5/5
	A/Mexico/4108/09	8.10 x 10 <sup>3</sup>	5/5
	A/New York/18/09	1.26 x 10 <sup>4</sup>	5/5
	A/Michigan/45/15	2.70 x 10 <sup>2</sup>	5/5
	A/New Caledonia/20/99	4.20 x 10 <sup>3</sup>	5/5
	A/Solomon Islands/03/06	5.62 x 10 <sup>1</sup>	5/5
	A/PR/8/34	5.01 x 10 <sup>2</sup>	5/5
	A/Wisconsin/67/22	3.87 x 10 <sup>1</sup>	5/5
	A/Connecticut/11/2023	9.33 x 10 <sup>3</sup>	5/5
	A/Baltimore/JH-22400/2022	8.90 x 10 <sup>3</sup>	5/5
H3N2	A/Brisbane/10/07	1.05 x 10 <sup>3</sup>	5/5
	A/Perth/16/09	1.87 x 10 <sup>3</sup>	5/5
	A/Kansas/14/17	1.51 x 10 <sup>5</sup>	5/5
	A/Norway/466/14	4.17 x 10 <sup>4</sup>	5/5
	A/Texas/50/12	1.26 x 10 <sup>3</sup>	5/5
	A/Victoria/361/11	6.20 x 10 <sup>2</sup>	5/5
	A/Wisconsin/67/05	4.70 x 10 <sup>2</sup>	5/5
	A/Michigan/173/20	5.20 x 10 <sup>3</sup>	5/5
A/Kumamoto/102/02	3.87 x 10 <sup>2</sup>	5/5	

Flu A Subtype	Pathogens	Concentration (TCID <sub>50</sub> /mL)	Results (#Pos/Total)
	A/Tasmania/503/20	1.41 x 10 <sup>4</sup>	5/5
H5N1	A/Chicken/Liaoning/SD007/2017	1.30 x 10 <sup>4</sup>	5/5
	A/Vietnam/1194/2004	1.10 x 10 <sup>4</sup>	5/5
H5N8	A/H5N8	3.67 x 10 <sup>2</sup>	5/5
H7N3	A/Waterfowl/Chenhu/367-1/2021	5.00 x 10 <sup>3</sup>	5/5

**Table 13. Summary of Flu B Analytical Reactivity with Flowflex Plus RSV + Flu A/B + COVID Home Test**

Flu B Lineages	Pathogens	Concentration (TCID <sub>50</sub> /mL)	Results (#Pos/Total)
Victoria	B/Malaysia/2506/04	3.16 x 10 <sup>3</sup>	5/5
	B/Michigan/01/21	1.17 x 10 <sup>4</sup>	5/5
	B/Singapore/WUH4618/21	3.90 x 10 <sup>4</sup>	6/6
	B/Washington/02/19	6.27 x 10 <sup>3</sup>	5/5
Yamagata	B/Florida/04/06	1.17 x 10 <sup>2</sup>	5/5
	B/Texas/06/11	3.80 x 10 <sup>3</sup>	5/5
	B/Utah/09/14	4.17 x 10 <sup>2</sup>	5/5
	B/Wisconsin/01/10	1.41 x 10 <sup>2</sup>	5/5

**Table 14. Summary of RSV Analytical Reactivity with Flowflex Plus RSV + Flu A/B + COVID Home Test**

RSV Subtypes	Pathogens	Concentration (TCID <sub>50</sub> /mL)	Results (#Pos/Total)
RSV A	RSV A NY-Wadsworth-22055420-01/2022	4.20 x 10 <sup>3</sup>	5/5
	RSV A Long	1.60 x 10 <sup>6</sup>	5/5
	RSV A2	1.60 x 10 <sup>6</sup>	5/5
RSV B	RSV B NY-Wadsworth-22055413-01/2022	3.53 x 10 <sup>3</sup>	5/5
	RSV B 18537	1.60 x 10 <sup>3</sup>	5/5
	RSV B, Isolate: 3/2015	1.69 x 10 <sup>3</sup>	5/5

### **Analytical Specificity: Cross-Reactivity and Microbial Interference**

Cross-reactivity and Microbial interference were evaluated by testing a panel of related viruses, high prevalence disease agents, and normal or pathogenic flora that are reasonably likely to be encountered in nasal swab specimens. Each microorganism was tested in the absence or presence of SARS-CoV-2, Influenza A, Influenza B, RSV A, and RSV B at a low concentration (3 x LoD) in triplicate.

No cross-reactivity or interference was observed with the following microorganisms when tested at the concentration presented in the table below.

**Table 15. Summary of analytical specificity of Flowflex Plus RSV + Flu A/B + COVID Home Test**

Microorganism	Working Concentration		Cross-reactivity Results	Interference Results
Adenovirus Type 7A	3.16 x 10 <sup>5</sup>	TCID <sub>50</sub> /mL	No Cross-reactivity	No Interference
Adenovirus 1	1.05 x 10 <sup>5</sup>	TCID <sub>50</sub> /mL	No Cross-reactivity	No Interference
<i>Bordetella pertussis</i>	5.04 x 10 <sup>8</sup>	CFU/mL	No Cross-reactivity	No Interference
<i>Candida albicans</i>	3.32 x 10 <sup>7</sup>	CFU/mL	No Cross-reactivity	No Interference
<i>Escherichia coli</i>	2.37 x 10 <sup>7</sup>	CFU/mL	No Cross-reactivity	No Interference
<i>Haemophilus influenzae</i>	9.85 x 10 <sup>7</sup>	CFU/mL	No Cross-reactivity	No Interference
<i>Neisseria mucosa</i>	6.52 x 10 <sup>8</sup>	CFU/mL	No Cross-reactivity	No Interference
<i>Corynebacterium jeikeium</i>	3.68 x 10 <sup>8</sup>	CFU/mL	No Cross-reactivity	No Interference
<i>Legionella pneumophila</i>	5.98 x 10 <sup>9</sup>	CFU/mL	No Cross-reactivity	No Interference
<i>Moraxella catarrhalis</i>	1.37 x 10 <sup>7</sup>	CFU/mL	No Cross-reactivity	No Interference
Mumps Virus	4.92 x 10 <sup>6</sup>	TCID <sub>50</sub> /mL	No Cross-reactivity	No Interference
<i>Mycobacterium tuberculosis</i>	4.60 x 10 <sup>7</sup>	CFU/mL	No Cross-reactivity	No Interference
<i>Mycoplasma pneumoniae</i>	1.37 x 10 <sup>7</sup>	CCU/mL	No Cross-reactivity	No Interference
<i>Neisseria meningitidis</i>	2.04 x 10 <sup>7</sup>	CFU/mL	No Cross-reactivity	No Interference
<i>Neisseria sicca</i>	3.23 x 10 <sup>9</sup>	CFU/mL	No Cross-reactivity	No Interference
Parainfluenza Virus Type 1	3.80 x 10 <sup>5</sup>	TCID <sub>50</sub> /mL	No Cross-reactivity	No Interference
Parainfluenza Virus Type 2	3.39 x 10 <sup>6</sup>	TCID <sub>50</sub> /mL	No Cross-reactivity	No Interference
Parainfluenza Virus Type 3	1.15 x 10 <sup>6</sup>	TCID <sub>50</sub> /mL	No Cross-reactivity	No Interference
Parainfluenza Virus Type 4	9.55 x 10 <sup>5</sup>	TCID <sub>50</sub> /mL	No Cross-reactivity	No Interference
<i>Pseudomonas aeruginosa</i>	5.50 x 10 <sup>8</sup>	CFU/mL	No Cross-reactivity	No Interference
<i>Staphylococcus aureus</i>	5.41 x 10 <sup>8</sup>	CFU/mL	No Cross-reactivity	No Interference
<i>Staphylococcus epidermidis</i>	3.52 x 10 <sup>8</sup>	CFU/mL	No Cross-reactivity	No Interference
<i>Streptococcus pyogenes</i>	2.36 x 10 <sup>8</sup>	CFU/mL	No Cross-reactivity	No Interference
<i>Streptococcus pneumoniae</i>	1.55 x 10 <sup>8</sup>	CFU/mL	No Cross-reactivity	No Interference
<i>Streptococcus salivarius</i>	4.07 x 10 <sup>7</sup>	CFU/mL	No Cross-reactivity	No Interference
Corona Virus Strain: 229E	2.09 x 10 <sup>5</sup>	TCID <sub>50</sub> /mL	No Cross-reactivity	No Interference
Corona Virus Strain: OC43	3.80 x 10 <sup>5</sup>	TCID <sub>50</sub> /mL	No Cross-reactivity	No Interference
Corona Virus, Strain: NL63	1.78 x 10 <sup>5</sup>	TCID <sub>50</sub> /mL	No Cross-reactivity	No Interference
Cytomegalovirus (CMV)	2.09 x 10 <sup>5</sup>	TCID <sub>50</sub> /mL	No Cross-reactivity	No Interference
Human Metapneumovirus	1.02 x 10 <sup>5</sup>	TCID <sub>50</sub> /mL	No Cross-reactivity	No Interference
Rhinovirus	2.09 x 10 <sup>5</sup>	TCID <sub>50</sub> /mL	No Cross-reactivity	No Interference
Measles Virus	2.53 x 10 <sup>5</sup>	TCID <sub>50</sub> /mL	No Cross-reactivity	No Interference
MERS-coronavirus	1.12 x 10 <sup>5</sup>	TCID <sub>50</sub> /mL	No Cross-reactivity	No Interference
<i>Lactobacillus plantarum</i>	3.13 x 10 <sup>8</sup>	CFU/mL	No Cross-reactivity	No Interference
Enterovirus	1.05 x 10 <sup>5</sup>	TCID <sub>50</sub> /mL	No Cross-reactivity	No Interference

Microorganism	Working Concentration		Cross-reactivity Results	Interference Results
<i>Pneumocystis jirovecii</i>	5.18 x 10 <sup>7</sup>	CFU/mL	No Cross-reactivity	No Interference
<i>Chlamydophila (Chlamydia) pneumoniae</i>	1.40 x 10 <sup>7</sup>	IFU/mL	No Cross-reactivity	No Interference
<i>Chlamydia trachomatis</i>	1.78 x 10 <sup>7</sup>	IFU/mL	No Cross-reactivity	No Interference
Epstein Barr Virus	4.02 x 10 <sup>7</sup>	CP/mL	No Cross-reactivity	No Interference
<i>Corynebacterium diphtheriae</i>	3.45 x 10 <sup>8</sup>	CFU/mL	No Cross-reactivity	No Interference
<i>Saccharomyces cerevisiae</i>	3.28 x 10 <sup>7</sup>	CFU/mL	No Cross-reactivity	No Interference
Human Coronavirus HKU1*: MINF-1596	1:10 dilution		No Cross-reactivity	No Interference
Human Coronavirus HKU1*: MINF-1597	1:10 dilution		No Cross-reactivity	No Interference
Human Coronavirus HKU1*: MINF-1598	1:10 dilution		No Cross-reactivity	No Interference
Human Coronavirus HKU1*: MINF-1601	1:10 dilution		No Cross-reactivity	No Interference
Human Coronavirus HKU1*: MINF-1602	1:10 dilution		No Cross-reactivity	No Interference

\* Human Coronavirus HKU1 (clinical specimens) listed in the upper Table 15 were confirmed using 510(k)-cleared BioFire® FilmArray® multiplex PCR syndromic testing (qualitative results only).

### Endogenous and Exogenous Interference Substances

The following medically relevant endogenous and exogenous interferents that may be encountered in the collected samples from the upper respiratory tract were evaluated. Substances that are commonly found on the hands were also tested. Each substance was tested in triplicate in the absence or presence of SARS-CoV-2, Influenza A, Influenza B, RSV A, and RSV B at a low concentration (3 x LoD). False positive results were detected for Flumist (live attenuated influenza vaccine, intranasal) at 15% v/v and 3% v/v for both Flu A and Flu B, and at 1.5% v/v for Flu A only; no cross reactivity was observed at 0.2% v/v. The performance of Flowflex Plus RSV + Flu A/B + COVID Home Test was not affected by rest of the interference substances tested at the concentration listed in the table below.

**Table 16. Summary of interference substance study on Flowflex Plus RSV + Flu A/B + COVID Home Test**

Interfering Substance	Working Concentration		Cross-reactivity Results	Interference Results
Equate Sore Throat Oral Anesthetic Spray (Phenol)	5%	v/v	No Cross-reactivity	No Interference

Interfering Substance	Working Concentration		Cross-reactivity Results	Interference Results
ZICAM Cold Remedy (Galphimia glauca, Luffa operculata, sabadilla)	15%	v/v	No Cross-reactivity	No Interference
Equate Nasal Four Nasal Spray (Phenylephrine HCl)	15%	v/v	No Cross-reactivity	No Interference
Nasal spray (Cromolyn sodium nasal solution)	15%	v/v	No Cross-reactivity	No Interference
Nasal spray (Oxymetazoline HCl)	15%	v/v	No Cross-reactivity	No Interference
Equate Nasal Spray Premium Saline Liquid Mist for Nasal Congestion	15%	v/v	No Cross-reactivity	No Interference
Equate Nasal Allergy Spray (Triamcinolone Acetonide)	15%	v/v	No Cross-reactivity	No Interference
Nasonex 24 HR Allergy (Mometasone furoate)	15%	v/v	No Cross-reactivity	No Interference
Nasal gel	1.25%	v/v	No Cross-reactivity	No Interference
Homeopathic nasal wash	15%	v/v	No Cross-reactivity	No Interference
Homeopathic allergy relief (histaminum hydrochloricum)	15%	w/v	No Cross-reactivity	No Interference
Ribavirin (RSV antiviral drug)	10	mg/mL	No Cross-reactivity	No Interference
Oseltamivir Phosphate (Tamiflu)	5	mg/mL	No Cross-reactivity	No Interference
Whole Blood	2.5%	v/v	No Cross-reactivity	No Interference
Hand sanitizer	15%	v/v	No Cross-reactivity	No Interference
Hand soap	10%	v/v	No Cross-reactivity	No Interference
Equate Budesonide Nasal Spray	15%	v/v	No Cross-reactivity	No Interference
Flonase sensimist allergy relief spray (Fluticasone furoate)	15%	v/v	No Cross-reactivity	No Interference
Fluticasone Propionate Nasal Spray	15%	v/v	No Cross-reactivity	No Interference
Tobramycin	50	µg/mL	No Cross-reactivity	No Interference
Dyclonine Hydrochloride	2	mg/mL	No Cross-reactivity	No Interference
Mucin (from bovine submaxillary glands)	2.5	mg/mL	No Cross-reactivity	No Interference
HALLS (Menthol)	3	mg/mL	No Cross-reactivity	No Interference
Sore Throat & Cough Lozenges (Benzocaine, Dextromethorphan HBr)	3	mg/mL	No Cross-reactivity	No Interference
Beclomethasone	5	mg/mL	No Cross-reactivity	No Interference
Mupirocin	10	mg/mL	No Cross-reactivity	No Interference
Flunisolide	5	mg/mL	No Cross-reactivity	No Interference
Dexamethasone	5	mg/mL	No Cross-reactivity	No Interference
Biotin	3500	ng/mL	No Cross-reactivity	No Interference
Leukocytes	2.5 x10 <sup>6</sup>	cells/mL	No Cross-reactivity	No Interference

Interfering Substance	Working Concentration		Cross-reactivity Results	Interference Results
Flumist (Influenza Vaccine Intranasal)	15%	v/v	Cross-reactivity with Flu A and Flu B	No Interference
	3%	v/v	Cross-reactivity with Flu A and Flu B	No Interference
	1.5%	v/v	Cross-reactivity with Flu A	No Interference
	0.2%	v/v	No Cross-reactivity	No Interference
Molnupiravir	10	mg/mL	No Cross-reactivity	No Interference
Remdesivir (covid-19 antiviral drug)	10	mg/mL	No Cross-reactivity	No Interference
Zanamivir	5	mg/mL	No Cross-reactivity	No Interference

### High Dose Hook Effect

No high dose hook effect was observed on the Flowflex Plus RSV + Flu A/B + COVID Home Test when tested with SARS-CoV-2 virus at a concentration of  $5.95 \times 10^6$  TCID<sub>50</sub>/mL, Flu A virus at a concentration of  $1.17 \times 10^5$  TCID<sub>50</sub>/mL, Flu B virus at a concentration of  $5.01 \times 10^5$  TCID<sub>50</sub>/mL, or RSV  $1.05 \times 10^6$  TCID<sub>50</sub>/mL respectively. The study used heat-inactivated SARS-CoV-2 but live Flu A, Flu B and RSV virus strains.

### Competitive Interference

Competitive interference among the test's analytes was evaluated with different combinations of low (2.5-3x LoD for single analyte) and high (highest achievable) concentrations of SARS-CoV-2, Flu A, Flu B, and RSV. The analytes were co-spiked and tested in triplicate. The results showed no competitive interference was observed between SARS-CoV-2, influenza A, influenza B, and RSV as listed in the table below.

**Table 17. Results of Competitive Interference**











Competitive Inhibition Study						
Test Sample		SARS-CoV-2 (Pos/Total)	Flu A (Pos/Total)	Flu B (Pos/Total)	RSV (Pos/Total)	Results
Analyte at High Con. (at least $10^5$ TCID <sub>50</sub> /ml)	Analyte at 2.5-3x LoD					
SARS-CoV-2	Flu A	3/3	3/3	0/3	0/3	No interference
	Flu B	3/3	0/3	3/3	0/3	No interference
	RSV	3/3	0/3	0/3	3/3	No interference

<b>Competitive Inhibition Study</b>						
<b>Test Sample</b>		<b>SARS-CoV-2 (Pos/Total)</b>	<b>Flu A (Pos/Total)</b>	<b>Flu B (Pos/Total)</b>	<b>RSV (Pos/Total)</b>	<b>Results</b>
<b>Analyte at High Con. (at least 10<sup>5</sup> TCID<sub>50</sub>/ml)</b>	<b>Analyte at 2.5-3x LoD</b>					
<b>Flu A</b>	<b>SARS-CoV-2</b>	3/3	3/3	0/3	0/3	No interference
	<b>Flu B</b>	0/3	3/3	3/3	0/3	No interference
	<b>RSV</b>	0/3	3/3	0/3	3/3	No interference
<b>Flu B</b>	<b>SARS-CoV-2</b>	3/3	0/3	3/3	0/3	No interference
	<b>Flu A</b>	0/3	3/3	3/3	0/3	No interference
	<b>RSV</b>	0/3	0/3	3/3	3/3	No interference
<b>RSV</b>	<b>SARS-CoV-2</b>	3/3	0/3	0/3	3/3	No interference
	<b>Flu A</b>	0/3	3/3	0/3	3/3	No interference
	<b>Flu B</b>	0/3	0/3	3/3	3/3	No interference

## BIBLIOGRAPHY

1. Shuo Su, Gary Wong, Weifeng Shi, et al. Epidemiology, Genetic recombination, and pathogenesis of coronaviruses. Trends in Microbiology, June 2016, vol. 24, No. 6: 490-502
2. Susan R. Weiss, Julian L. Leibowitz, Coronavirus Pathogenesis, Advances in Virus Research, Volume 81: 85-164

## Index of Symbols

	Manufacturer		Date of manufacture
	Contains sufficient for <n> tests		Catalogue number
	<i>In vitro</i> diagnostic medical device		Use-by date
	Consult instructions for use		Batch code
	Temperature limit		Do not reuse
	Do not use if package is damaged		

  
**ACON Laboratories, Inc.**  
 5850 Oberlin Drive, #340  
 San Diego, CA 92121, USA  
[flowflexcovid.com](http://flowflexcovid.com)  
 Customer Support: 1-800-838-9502

Part Number: 1150003190  
 Effective Date: 2025-10-28